

Rebar Cage Drawing

PART NO	ANSI COMBO UNIT	HA	HB	H	HL	T-1
DY58870A001	101	17.00	50.00	9.00	41.00	6.50
DY58870A002	102	23.00	61.00	14.00	46.00	9.75
DY58870A003	201	23.00	55.00	14.00	46.00	6.50
DY58870A004	202	23.00	61.00	14.00	46.00	7.00
DY58870A005	203	29.00	73.00	20.00	64.00	9.75
DY58870A006	301	29.00	73.00	20.00	64.00	6.00
DY58870A007	302	31.00	85.00	22.00	76.00	7.00
DY58870A008	303	31.00	103.00	22.00	93.00	9.00

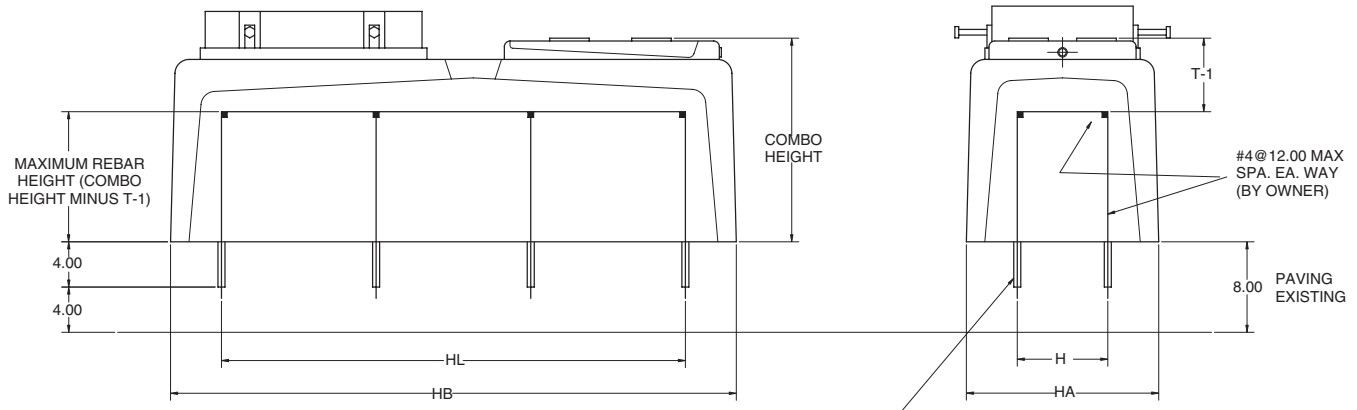

FIELD DRILL .625y X 6.00 DEEP HOLES IN EXISTING CONCRETE. INSTALL #4 REBAR WITH "HILTI" HY-150 ADHESIVE OR EQUAL PER MANUFACTURER'S INSTRUCTIONS.

PATTERN NO.		DIMENSIONING AND TOLERANCING PER ANSI Y14.5M		ORDER NO.		Byron Jackson Pumps Duco Process Pumps Stok Engineered Pumps United Centrifugal Pumps Wilson-Snyder Pumps Pump Division		
CARTING DWG.	THIS MATERIAL IS THE PROPERTY OF POLYSHIELD CORP. AND IS FURNISHED FOR THE PURPOSE INDICATED. ANY AND ALL CONFIDENTIAL, PROPRIETARY, PATENT AND OTHER RIGHTS, IN THE SUBJECT MATTER BEING RETAINED INCLUDING ANY EXCLUSIVE RIGHTS OF USE AND/OR MANUFACTURE AND/OR SALE. POSSESSION OF THIS MATERIAL DOES NOT CONVEY ANY PERMISSION TO REPRODUCE THIS MATERIAL IN WHOLE OR IN PART, OR MANUFACTURE INFORMATION SUCH PERMISSION THEREON OR USE THE CONFIDENTIAL OR PROPRIETARY INFORMATION SUCH PERMISSION TO BE GRANTED ONLY BY SPECIFIC AUTHORIZATION IN WRITING ISSUED BY A OFFICER OR OTHER AUTHORIZED AGENT OF POLYSHIELD CORP., ITS DIVISIONS OR SUBSIDIARIES.	UNLESS OTHERWISE SPECIFIED:		DRAWN BY	DATE	DRAWING TITLE		
PART NUMBER		SEE CHART	ALL DIMENSIONS ARE IN INCHES	DO NOT SCALE DRAWING	CHECKED BY	DATE	REINFORCEMENT BAR LAYOUT	
HYDRAULIC DWG.			TOLERANCES FRACTIONS XX ± 0.1 XXX ± 0.01 XXXX ± 0.005	DECIMALS XX ± .50	DESIGN APP'D BY	DATE	SIZE	DRAWING NO.
△ MACHINER/ALTER FROM			FINISH ALL MACHINED SURFACES TO 250	BREAK ALL CORNERS AND SHARP EDGES .005/0.00, RADIUS ALL FILETS .010/.045 R	MANF. APP'D BY	DATE	D	D58870A
MATERIAL		DRILL HOLES FINISHED AS DRILLED COUNTERBANK 60° X .56/0.01 DEEP CHAMFER ALL THREADED HOLES WITH A 60° COUNTERBANK TO THE MAJOR DIAMETER .610/.005 SCREW THREAD STANDARDS PER FED-STD-H8B		QA APP'D BY	DATE	SCALE	TYPE	
						NONE	DO NOT SCALE DRAWING	
							No. STAGES WEIGHT SHEET 1 OF 1	

REVISIONS						
LTR	REV. BY	DESCRIPTION	E C N	DATE	CHK'D	ENG.
1	WBF	RELEASED FOR PRODUCTION PER EDR 0201 38		5-30-02		